

DTV SHREDDER

Owners Manual

DTV
MOTOR CORPORATION



This page left intentionally blank

To the Owner

Congratulations on your purchase of the Electric DTV Shredder! This Owner's/Operator's manual will provide you information regarding safe operation, operational instructions, maintenance, and care. Fully understanding this manual and following all of the instructions herein will provide the knowledge needed for optimal experience of the DTV Shredder.

For questions regarding operation and maintenance for this DTV, Please email support@dtvmotorcorp.com.

Safety - Notice

This DTV is intended for use by riders aged 16 or older. Never allow anyone to operate this vehicle who is under age

16. See dealer for instructions and demonstration of proper riding technique.

THIS DTV IS NOT A TOY AND COULD BE DANGEROUS TO OPERATE. A DTV handles differently from other vehicles including motorcycles, ATV's and cars. A collision or rollover can occur quickly, even during routine maneuvers such as turning, driving on hills and over obstacles.

Reading the Owner's/ Operator's Manual

It is important this manual is read **fully and carefully** by the DTV owner and all operators. Never allow anyone to operate the DTV without first reading and understanding the Owner's/Operator's manual.

This Owner's/ Operator's manual is available online for free using the QR code on the warning labels on the Electric DTV Shredder. A physical copy may also be requested by emailing support@dtvmotorcorp.com.

Notice

DTV Motor Corp is concerned about the environment and believes in conserving and protecting all natural resources. For this reason, owners should recycle, trade in, or dispose as appropriate, batteries, oil and tracks.

This manual is based on the latest product information available at the time of publication. DTV Motor Corp has a policy of continually improving its products. Due to improvements, or other changes, there may be some discrepancies. We reserve the right to make product changes at any time, without notice and without incurring any obligation to make the same or similar changes to vehicles previously built or sold.

To emphasize special important information in the manual, please note the following:



This is the alert symbol. The symbol means **ATTENTION!**
BECOME ALERT! YOUR SAFETY IS INVOLVED.

To emphasize important safety information, the word **WARNING**, with the alert symbol, has special meaning:

WARNING

Indicates a potential hazard that could result in **SEVERE INJURY** or **DEATH** to the operator, bystander or person inspecting or repairing the DTV

To emphasize important information, the word **CAUTION** has special meaning:

CAUTION

Indicates special precautions that must be taken to avoid damage to the DTV.

To emphasize important information, the word **NOTE** has special meaning:

NOTE:

Indicates key information to make procedures easier or clearer to understand.

WARNING or CAUTION

The first part will identify a **POTENTIAL HAZARD.**

The second part will describe **WHAT COULD HAPPEN** if the warning or caution is ignored.

The third part will describe **HOW TO AVOID THE HAZARD.**

TABLE OF CONTENTS

WARNING LABEL LOCATION.....	1	RIDING IN COLD WEATHER.....	30
WARNING LABELS.....	2	PROPER CLOTHING.....	30
SAFETY.....	4	PRE-RIDE INSPECTION.....	30
FEATURES AND CONTROLS.....	5	COLD CONDITIONS START UP.....	31
BRAKE LEVER.....	5	RIDING ON SNOW AND ICE.....	32
THUMB THROTTLE LEVER.....	5	LOADING GUIDELINES.....	33
SAFETY LANYARD.....	5	AFTER MARKET PARTS.....	33
HANDLE LOCK RELEASE LEVER.....	5	MAINTENANCE.....	34
BATTERY.....	6	MAINTENANCE CHART.....	35
BATTERY INSTALLATION.....	6	BRAKES.....	37
BATTERY RESET.....	8	STEERING.....	37
IMPORTANT BATTERY INFO.....	9	CHAIN AND SPROKET.....	38
CHARGING.....	11	TRACKS.....	39
BREAK-IN.....	14	LUBRICATION POINTS.....	41
ADDING COOLANT.....	14	FASTENER TORQUE VALUES.....	42
PRE-RIDE INSPECTION.....	15	STORAGE.....	43
RIDING THE SHREDDER.....	16	WASHING THE DTV.....	44
WARNINGS.....	17	TRANSPORTING.....	44
RIDING GEAR.....	17	TROUBLE SHOOTING.....	45
FIRST USE.....	19	SPECIFICATIONS.....	46
RIDING ON HILLS.....	26	WARRANTY.....	47
RIDING OVER OBSTACLES.....	27	VIN NUMBER LOCATION.....	50
GOING REVERSE.....	28		
RIDING THROUGH WATER.....	29		

WARNING LABEL LOCATIONS

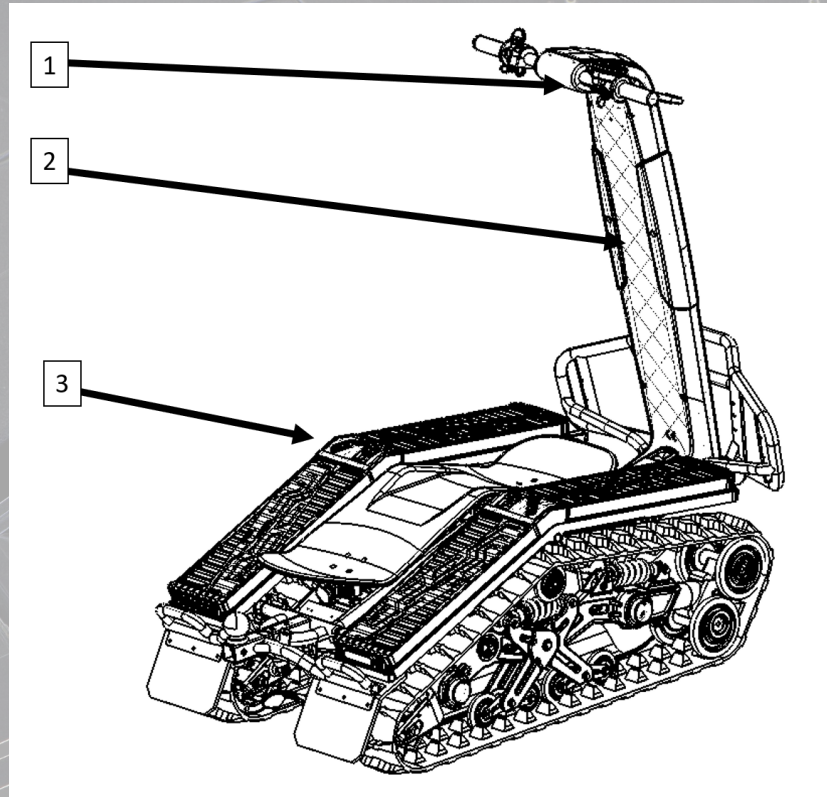

WARNING LABELS

 **WARNING**

DO NOT OPERATE THIS VEHICLE WITHOUT CONSULTING THE OWNER'S MANUAL. FAILURE TO DO SO CAN RESULT IN INJURY OR DEATH.

FOLLOW ALL INSTRUCTIONS AND WARNINGS

NEVER OPERATE:

- At speeds too fast for your skills or the conditions
- On public roads
- With more than one person on the vehicle
- In the dark or in other low light conditions
- While under the influence of drugs or alcohol
- On inclines of more than 25°
- DO NOT ADJUST HANDLE POSITION WHILE VEHICLE IS ON

ALWAYS:

- Use proper riding techniques to avoid overturns on hills, rough terrains, and in turns
- Avoid traversing a hill without advanced skills
- Ensure handle is securely locked before riding

- Never perform jumping maneuvers on the DTV or drop it from any height
- DOT approved helmet is strongly advised along with appropriate eye protection
- Wear appropriate footwear to ensure good grip with the board deck to minimize risk of injury

 **WARNING**

Keep all loose clothing and extremities away from sprockets, chains, rollers, and tracks.

 **How To Ride**

 **Manuals**

ELECTRIC SHREDDER WARNINGS:
Failure to heed these warnings can lead to battery failure, vehicle damage, or fires as well as injury or death

- Do not puncture the batteries
- Always follow proper local regulations for the transport of lithium-ion batteries
- Do not submerge the DTV Shredder
- Operate the DTV Shredder in temperatures between -20C to 50C
- Store the DTV Shredder in temperatures between -5C and 35C
- **DO NOT PLUG OR UNPLUG THE BATTERIES WHILE THE VEHICLE IS ON**
- Only use approved chargers to charge the batteries
- Do not let the batteries completely drain - keep the batteries charging with the 5A charger if storing for a long period

 **WARNING**

DO NOT PLUG OR UNPLUG BATTERY WHILE THE VEHICLE IS ON

WARNING LABELS



OPERATION WARNING

Use caution when applying brakes. Avoid using brakes at high speeds. Sudden braking may result in a rollover and personal injury. Always attempt to decrease speed by gradually letting off the throttle first. Sudden release of the throttle may also result in a rollover. Smooth throttle control is paramount to maintaining control of the vehicle

Never operate the DTV at night or in low light conditions

SAFETY

Never allow anyone under the age of 16 to operate this DTV.

Always wear an approved helmet. Approved helmets in the USA and Canada bear a U.S. Department of Transportation (DOT) label. Approved helmets in Europe, Asia and Oceania bear the ECE 22.05 label.

Always wear over the ankle boots, eye and hearing protection, gloves, long sleeve shirt, long pants, elbow, shin and knee pads while operating this DTV.

Never take a passenger on this DTV. This DTV is designed for one operator only.

Never operate this DTV on paved surfaces and/or public roads.

Always go slowly and pay attention to unfamiliar terrain. Be alert to changing terrain conditions when operating the DTV.

Never take drugs or alcohol before or during operating this DTV.

Never traverse, climb or go down a hill that has over a 25° maximum incline. Avoid hills with loose or slippery terrain.

Never attempt to traverse a hill until you feel comfortable enough with your riding skill level.

Always follow proper procedures on hills. Follow the instructions in this manual for traversing, climbing or going down hills. Follow the proper instructions located in this manual if DTV is stalled on a hill.

Never attempt wheelies, jumps or any other type of stunts on this DTV.

Do not drop DTV from any height.

Always follow the pre-ride inspection procedures and maintenance procedures located in this manual before use.

Always go slow on terrain that is not familiar, be alert, unexpected obstacles can throw the rider off balance.

Always keep both hands on the handlebars and both feet on the Deck, doing so will help the operator be ready for unexpected situations.

Always follow the proper turning procedures listed in this manual. Practice turning at slow speeds before attempting to turn at higher speeds.

Always apply the parking brake or brake lever clamp before starting the Shredder.

Always ensure the handle is securely locked before riding. Be careful not to press the handle lock while riding.

Always use caution when applying brakes. Avoid using brakes at high speeds. Sudden braking may result in a rollover and personal injury.

Always attempt to decrease speed by gradually letting off the throttle first. Sudden release of the throttle may also result in a rollover. Smooth throttle control is paramount to maintaining control of vehicle.

FEATURES AND CONTROLS

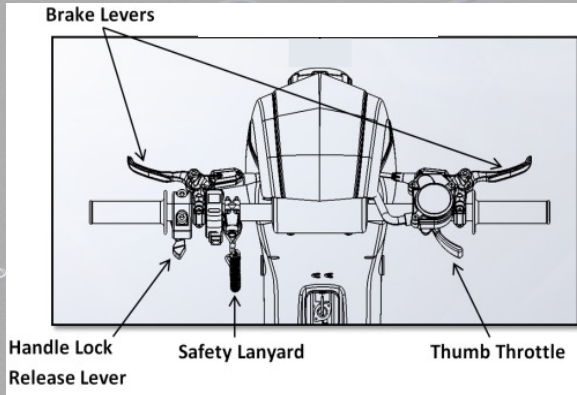

Brake Levers: Brakes are applied when the brake levers are pulled simultaneously in a controlled manner.

Handle Lock Release Lever: The Handle can be adjusted when the Handle Lock Release Lever is pushed toward the hand grip.

Thumb Throttle Lever: Throttle is applied by depressing the Thumb Throttle.

Safety Lanyard: The vehicle will shut down immediately when the Safety Lanyard is removed from the handle.

Note: Always attach the Safety Lanyard to your person when operating the vehicle.

Note: Make sure the Safety Lanyard is attached before attempting to ride the vehicle. The Vehicle will not run without the Safety Lanyard attached.

BATTERY

Battery Installation

The Batteries should be placed as shown:

- 1) Unscrew and remove the center knob and cover exposing the battery terminals.
- 2) Charge each battery individually using the provided 5A charger before first time use. (See First Time Battery Charging Page for more information)
- 3) Once charged, plug each terminal of the battery into the terminal for the unit.
- 4) Try to pull the terminals apart to ensure they are securely connected to each other.
- 5) Reattach the center knob and cover.

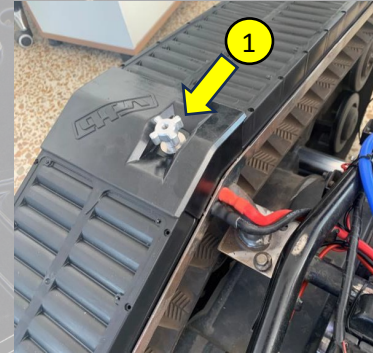

Each battery pack should look like this:



Male Battery Terminal



BATTERY

Battery Installation

Turning on the Vehicle and Checking the Battery

- 1) Press the **ON/OFF** button at the top of the handle to turn on the vehicle.
- 2) If the vehicle has power, the battery gauge will turn on with a green light.
- 3) If the light didn't turn on, it means the battery is in "SLEEP MODE" and will require a five second charge cycle to "WAKE UP".
- 4) **IMPORTANT:** For the first charge, follow the first time charging sequence and provided on the First Time Battery Charging page.



BATTERY

Battery Reset

The DTV battery can be reset at any time by pressing the green button located in the picture to the right. This will enable the charge and discharge modes of the battery.

The button should be used under the following conditions:

1. The battery has entered “Sleep Mode” (green light is off).
Note: The battery may need to be plugged into a charger to activate it from “Sleep Mode”
2. Charging the battery is non-responsive.

The button should not be used under the following conditions:

1. The battery has repeatedly switched off while charging or discharging, indicating a problem. Contact DTV Support in this case.
2. There is a known defect/damage with the battery.
3. If the battery is hot or stored in a hot environment.
4. If the battery is wet or in contact with water.

Note: When the green light is on the battery is “Active” and ready to use. If the battery is functioning normally and the light turns off, then the battery has entered “Sleep Mode”. This happens if the battery has not been used and to save the battery.

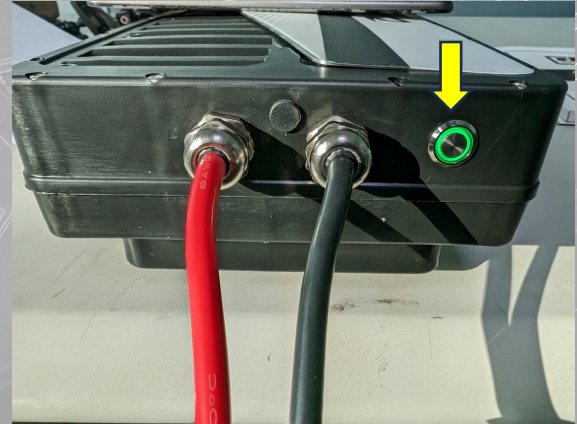

BATTERY

Important Battery Information

IMPORTANT: The batteries are designed to enter into sleep mode after 48 hours of nonuse. If the batteries don't get used within one month or more, it is very important to periodically charge them to prevent battery damage. If the batteries get to a low voltage state they will be **UNABLE TO BE CHARGED** and will need to be safely disposed of and replaced.

IMPORTANT: It's better for the batteries to be charged separately for the first time, after which they can be plugged into the vehicle one-by-one to check the battery voltage separately. This will ensure the battery voltage is equalized **BEFORE** plugging **ALL** four of the batteries together.

Note: The battery configuration is 12S lithium battery and has the following characteristics:

The nominal voltage: $3.6 \times 12 = 43.2$ Volts.

The MAX voltage: $4.2v \times 12 = 50.4$ Volts

The MAX current: **100A / Pack**

The MAX charge current: **18A / Pack**

BATTERY

Important Battery Information

Battery Type: 43.7V, 25AH Lithium-Ion
Operating temperature range: -40 to +60 °C
Charging temperature range: 0 to +60 °C
Storage conditions: less than 23 °C with low humidity, charge batteries once per year



WARNING

- The battery can catch fire, explode, or leak if the safety items listed below are not followed:
- Do not immerse the battery in water or seawater. Keep the battery in a cool dry environment during storage.
- Do not mix the battery with a different type (such as dry battery) or a battery with different performance characteristics altogether.
- Keep all batteries out of the reach of children. Consult a doctor immediately if battery or electrolyte is swallowed.
- Do not use or leave the battery near a heat source such as a fire or heater.
- When re-charging, use the battery charger specifically for that purpose.
- Do not reverse the positive (+) and negative (-) terminals.

- Do not connect the battery to an electrical outlet.
- Do not dispose the battery in fire or heat.
- Do not short-circuit the battery by directly connecting the positive (+) and negative (-) terminals with metal objects such as wire.
- Do not transport or store the battery together with metal objects such as necklaces, hairpins etc.
- Do not strike or throw the battery against a hard surface.
- Do not directly solder the battery
- Do not pierce the battery with a nail or sharp object.
- Never disassemble the battery in any way.

CAUTION

- Do not use or leave the battery at a very high temperature (for example, in strong direct sunlight or in a vehicle in extremely hot weather). Otherwise the battery can overheat catching fire or its performance will degenerate and its service life will be shortened.

- Do not use in a location where static electricity is prevalent, otherwise the safety devices may be damaged, causing a harmful situation.
- If electrolyte gets into eyes due to leakage of battery, do not rub the eyes! Rinse eyes with clean running water and seek medical attention immediately. Otherwise, it may injure eyes or cause loss of sight.
- If the battery gives off an odor, generates heat, becomes discolored or deformed, or in any way appears abnormal during use, recharging or storage, immediately remove it from the device or battery charger and place it in a contained vessel such as a metal box.
- If battery terminals are contaminated, clean the terminals with a dry cloth. Otherwise, power failure or charge failure may occur due to poor connection between the battery and the electronic circuitry.
- Be aware, discarded batteries may cause fire. 100% discharge the battery and tape the battery terminals to insulate them before disposal.
- ALWAYS use DTV certified batteries. Using Non-Certified batteries can be dangerous and will VOID your warranty.

BATTERY

Battery Charging

The DTV can be charged in two ways:

- 1) The first way is to charge the vehicle is by charging the battery packs individually. This can be done by plugging directly into the battery pack plug. **This is the preferred method for first time charging using the Standard 5A charger.**
- 2) The second way is to charge all four packs together by plugging directly into the rear vehicle charge port.

IMPORTANT: Charging Process

- Let battery cool down to ambient temperature before charging.
- Put batteries in an isolated area, away from other flammable materials.
- Always have fire extinguisher for emergency use.



BATTERY

First Time Battery Charging

The DTV First Time Charging:

- 1) Remove the center knob and battery cover, exposing the battery and terminals.
- 2) Remove the batteries from the DTV unit.
- 3) Using the standard 5A charger, plug the first battery into the charger until fully charged. Estimated 2.5 hours per battery.
- 4) Charge all 4 batteries individually with this 5A charger
- 5) Once all 4 batteries are charged, plug each battery into the vehicle.



3

5A Charger



3

IMPORTANT: Charging Process

- Let battery cool down to ambient temperature before charging.
- Put batteries in an isolated area, away from other flammable materials.
- Always have fire extinguisher for emergency use.

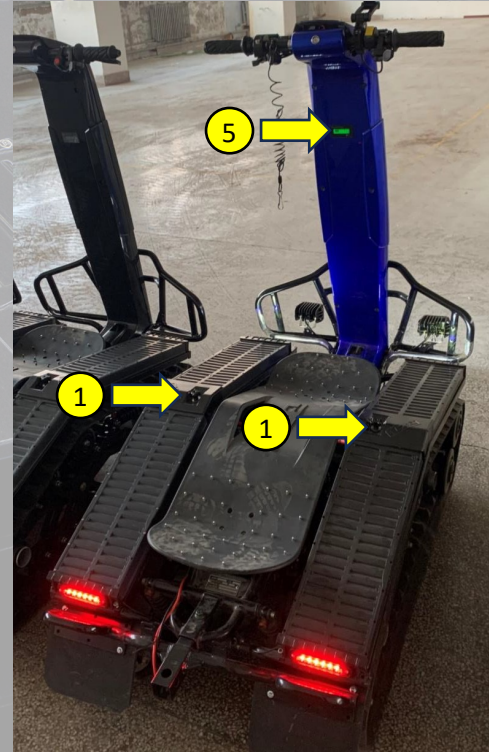

5

1

1

BATTERY

Battery Charging Continued

There are two types of chargers for the DTV:

1) Low power 5A charger

- Solid Green Light – Charging Complete
- Flashing Yellow Light - Charging
- Flashing Red Light – Fault or Issue
 - Clear fault by unplugging and plugging in the charger and battery

2) High power 30A charger

- Solid Green Light – Charging Complete
- Flashing Green Light – Above 80% Charge
- Flashing Red Light – Below 80% Charge

The battery will charge within the following times:

Rear vehicle charge port

5A = 10 hours charging time

30A = 2.5 hours charging time

Individual pack charging

5A = 2.5 hours charging time

30A = 1 hours charging time

30A Charger



5A Charger



- The high power charger has one charge output

- The low power charger has one charge output



WARNING

For proper charging of the batteries, do not charge when the batteries are below 0°C. In the case the batteries are below 0°C, the batteries can be warmed up by riding the Shredder or by being stored in a place above 0°C.

BREAK-IN

Adding Coolant

Steps to fill coolant reservoir:

- 1) Remove top steering board to gain easier access to the reservoir (8 screws).
- 2) Remove black cap for reservoir.
- 3) Use pre-mixed general purpose automotive coolant for use with aluminum parts. **Does not have to be Chevron Delo brand.**
- 4) Using a funnel add approximately 0.5L of coolant slowly to the reservoir. The pump will circulate the fluid once the unit has power.
- 5) Once the unit has power check the reservoir again.
- 6) Fill the reservoir to 1" below the spout.
- 7) Reattach the reservoir cap.
- 8) Reattach the steering board.

Note: if you overfill the reservoir, the system will automatically dump the excess. This is normal and not a leak of the system.

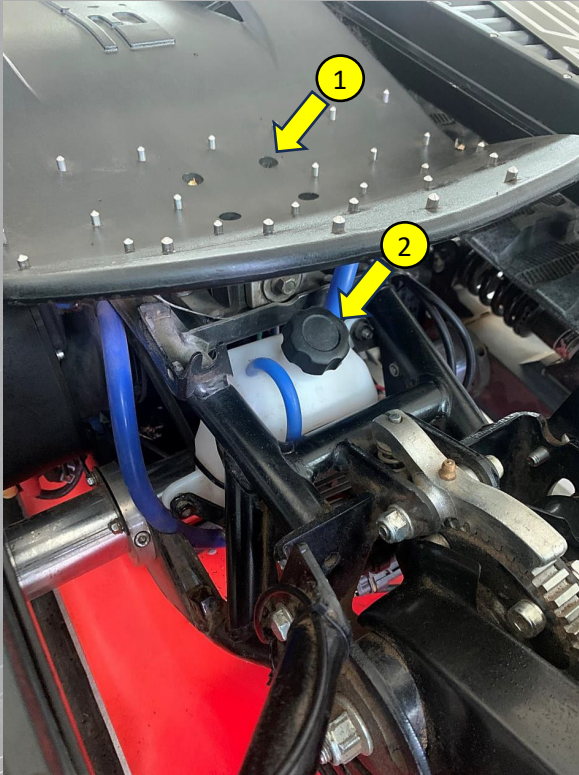

**General Purpose
Coolant for
Aluminum Parts**

14



BREAK-IN

Pre-Ride Inspection

Inspecting and checking the condition of the DTV before each ride is important. Following the pre-ride check list will help ensure that you do not have mechanical problems which could result in injury or becoming stranded. Make sure the DTV is in good operating condition before each ride.



WARNING

Failing to inspect and maintain your DTV could be hazardous.

Not following the pre-ride inspection procedures could result in losing control of the DTV resulting in an accident or damage to the DTV

Always perform a Pre-ride inspection before each ride.



WARNING

Performing maintenance and checks while the engine is running could be hazardous.

You could be severely injured by moving parts or hot surfaces.

Never perform maintenance or check procedures while the engine is running with the exception of checking the engine stop switch or throttle.

Never remove all the free play from the brake handle lever.

Doing so could cause brake failure due to thermal expansion of the fluid.

WHAT TO CHECK	
STEERING	<ul style="list-style-type: none">• Smoothness• No restriction of movement
BRAKES	<ul style="list-style-type: none">• Brake pad wear• Proper brake lever play
TRACKS	<ul style="list-style-type: none">• Check for exposed and frayed reinforcement threads as well as cracks
BATTERY	<ul style="list-style-type: none">• Ensure not fully discharged• Casing has no signs of cracks or damage
THUMB THROTTLE	<ul style="list-style-type: none">• Thumb throttle snaps back when released• Operates freely• Has correct free play
ENGINE STOP SWITCH	<ul style="list-style-type: none">• Switch shuts off vehicle when activated
COOLANT LEVEL	<ul style="list-style-type: none">• Correct coolant level
DRIVE CHAIN	<ul style="list-style-type: none">• Proper tension• Lubricated• No excessive wear or damage
GENERAL CONDITION	<ul style="list-style-type: none">• All nuts and bolts are tight• No rattles from motor or frame while running

RIDING THE SHREDDER

Warnings



WARNING

Riding this DTV on paved surfaces could be hazardous.

Riding on paved surfaces, including parking lots, sidewalks, driveways, and streets can cause loss of control resulting in severe injury or death. DTV Tracks are designed for off-road use only, paved surfaces adversely affect handling and control.

Avoid riding DTV on paved surfaces. If you must cross a paved surface, go slow and do not make sudden turns or stops.



WARNING

Carrying a passenger on this DTV could be hazardous

Carrying a passenger could cause loss of control resulting in severe injury or death to the operator and/or the passenger.

This DTV is designed for one operator and no passengers. Never allow a passenger.



WARNING

Operating this DTV in an irresponsible manner which includes jumping, doing wheelies or other stunts could be hazardous.

Jumping, doing wheelies or other stunts could result in loss of control of the DTV resulting in severe injury or death.

Never attempt stunts, such as jumping or doing wheelies.



WARNING

Riding this DTV on any public road or highway could be hazardous.

You could collide with another vehicle if you ride on public roads or highways resulting in severe injury or death.

Never ride on public roads and highways.



WARNING

Standing platform (Deck) can become very hot in direct sunlight.

RIDING THE SHREDDER

Warnings Continued



WARNING

Depressing the thumb throttle to full throttle when starting off could be hazardous.

The DTV could jolt forward causing the machine to become unstable.

Always open the throttle gradually when taking off from a stopped position.



WARNING

Operating this DTV at excessive speeds could be hazardous.

Riding at excessive speeds increases your chances of losing control of the DTV, which could result in severe injury or death.

Always go at a speed that is proper for the terrain, visibility, operating conditions, operator skill, and operator experience. Always know the terrain before riding.



WARNING

Removing hands from the handlebars and/or feet from the deck while operating the DTV could be hazardous.

Removing both or one hand from the handlebars and/or feet from the Deck could result in loss of control of the DTV resulting in severe injury or death.

Always ride with both hands on the handlebars and both feet on the Deck while operating the DTV.

RIDING THE SHREDDER

Riding Gear

Wearing a helmet (1) can prevent a severe head injury. Whenever riding a DTV always wear a helmet that meets or exceeds established safety standards. Approved helmets in the USA and Canada bear a U.S. Department of Transportation (DOT) label. Approved helmets in Europe, Asia and Oceania bear the ECE 22.05 label. The ECE mark consists of a circle surrounding the letter E, followed by the distinguishing number of the country which has granted approval. The approval number and serial number will also be displayed on the label.

Always wear shatter proof eye protection when riding a DTV such as face shield or goggles (2). Good eye protection, hearing protection as well as a helmet and protective riding gear are mandatory when riding a DTV.

Wear protective clothing: Gloves (3), long pants (4), over the ankle boots (5), long sleeved jacket (6), elbow and knee pads (7).

Riding a DTV exposes the rider to many hazards, wearing protective clothing can help protect the rider from injury.



WARNING

Riding a DTV without a helmet, eye and hearing protection, as well as protective clothing can be hazardous.

Riding a DTV without a helmet increases the chance of severe head injury or death in the event of an accident.

Riding a DTV without eye protection such as a face shield or goggles could result in severe injury in the event of an accident.

Riding a DTV without protective clothing; over the ankle boots, long pants, gloves, long sleeve shirt, elbow and knee pads could result in severe injury in the event of an accident.

Always wear a Helmet, eye and hearing protection, long pants, long sleeve shirt, over the ankle boots, gloves, elbow and kneepads when riding a DTV.

RIDING THE SHREDDER

First Use

19

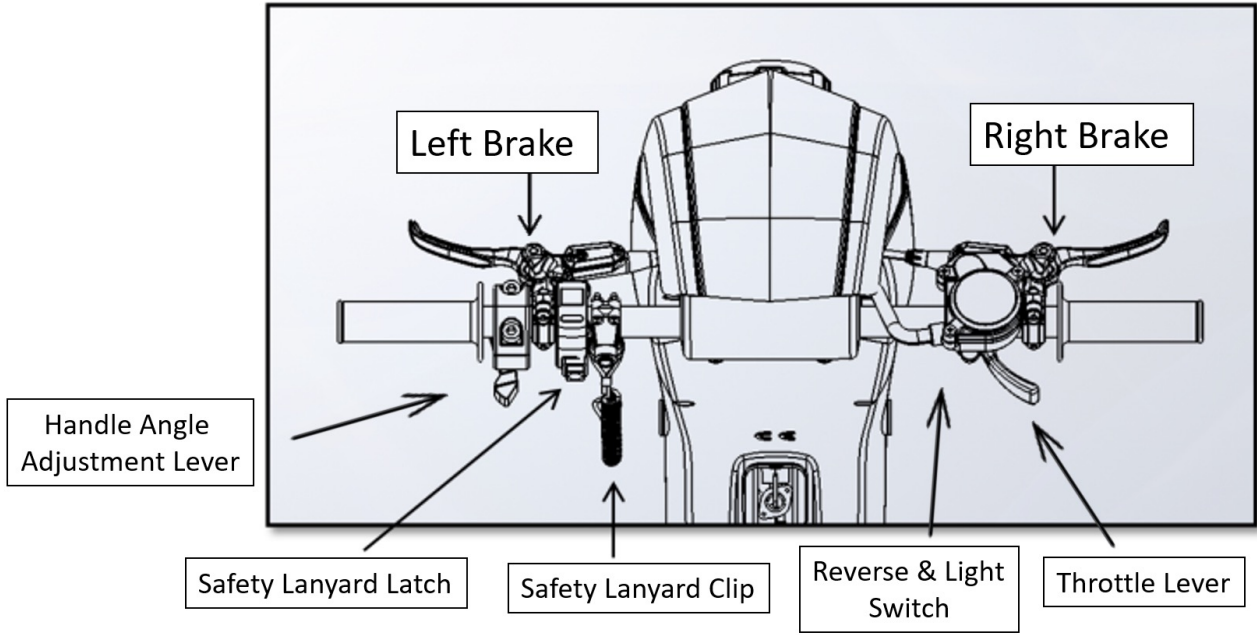

RIDING THE SHREDDER

First Use

Step 1: Turning on the Vehicle

Turning on the vehicle:

1. Ensure safety lanyard is installed
2. Clip the lanyard to a point on the rider
3. Compress parking brake
4. Press ON/OFF button to turn ON Vehicle
5. Look for green light on battery gauge and battery level is sufficient
6. If everything seems normal, release parking brake and begin to ride.

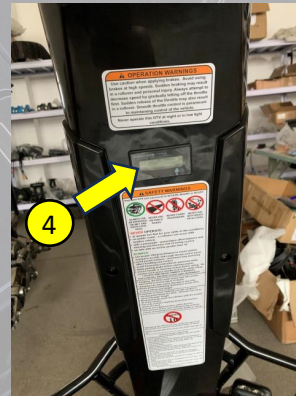

RIDING THE SHREDDER

First Use

Step 2: Engaging the Throttle

Using the Throttle and Reverse:

1. The Red Switch controls the forward and reverse gears. When the "I" position is engaged you will move forwards, and engaging the "O" will put the unit in reverse.
2. The Black Switch controls the lights on the Unit.
3. The lever under the handle bar is the throttle control. The first $\frac{1}{4}$ of the movement is a dead-band zone and will not engage the throttle. After this the DTV will begin to move based on the input provided by the rider.

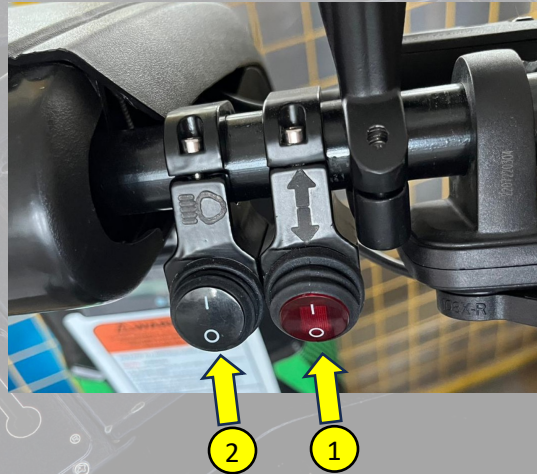

RIDING THE SHREDDER

First Use

Step 3: Steering the Vehicle

The E DTV vehicle has 2 steering situations

- 1) **ZERO TURN** - Not moving + full board tilt + throttle lever partially pressed. This will result in the vehicle trying to turn on the spot by having one track go forward and the other going in reverse.
- 2) **NORMAL TURN** - Moving + board tilt + throttle partially pressed. This will cause the inner track to slow down and the outer track to speed up resulting in turning. The more you tilt the board the more it will try to turn.



RIDING THE SHREDDER

First Use

Step 3: Steering the Vehicle - ZERO TURN

Not moving + full board tilt + throttle lever partially pressed. This will result in the vehicle trying to turn on the spot by having one track go forward and the other going in reverse.

The conditions for this steering type are the following:

The vehicle must be in a stationary position.

The board must be tilted to the full direction of travel.

The throttle lever must be activated to a relatively high position.

The motors must be warmed up. This function can also be impeded by tracks being overloaded from debris caught in the tracks, or the tracks being jammed.

This type of steering has a maximum speed differential. If the speed exceeds a preset amount, the ZERO TURN steering will exit and be shifted over to the normal steering.

Troubleshooting:

If the vehicle is not performing the ZERO TURN steering method:

Ensure vehicle is on a flat surface.

Ensure the tracks have proper tension and are not coming off the tracks drive sprocket.

Ensure there is no debris lodged in the tracks.

Ensure the motors have operated for enough time to warm them up sufficiently.

RIDING THE SHREDDER

First Use

Step 3: Steering the Vehicle – Normal Turn

Moving + board tilt + throttle partially pressed. This will cause the inner track to slow down and the outer track to speed up resulting in turning. The more you tilt the board the more it will try to turn.

The conditions for this steering type are the following:

- The vehicle must be moving.

- The board must be tilted to either direction to any degree.

- The throttle lever must be activated to maintain a constant forward or reverse direction.

This type of steering has a speed sensitive function. This means if the vehicle increases its speed, the steering will gradually become less. At higher speeds, the steering rate will become significantly decreased which makes the vehicle more stable. Depending on the setting used in the DTV APP, the high-speed steering function can be adjusted to varying degrees. Depending on skill level, the steering rate and ability should be adjusted accordingly.

Troubleshooting:

If the vehicle is not turning as expected, try the following:

- Ensure vehicle is on a flat surface

- Ensure the tracks have proper tension and are not coming off the tracks drive sprocket

- Ensure there is no debris lodged in the tracks.

- Ensure the motors have operated for enough time to warm them up sufficiently.

RIDE THE SHREDDER

First Use

How to Ride the DTV Shredder

The DTV Shredder is unlike anything else in Powersports. Understanding the Shredder's two key control mechanisms is critical – Throttle and Deck Control.

Throttle: Engaging the throttle causes forward momentum as with most other Powersports

Deck Control: Directional steering of the DTV Shredder is controlled by leaning left to turn left and leaning right to turn right much like a skateboard or snowboard. When directional pressure is applied to the deck, the Shredder will respond by turning. Much like a jet ski, turning is only possible by applying the throttle for forward momentum.

Leaning from side to side on the deck will influence the motor speed within the transmission which causes one track to rotate faster than the other thus causing a turning motion. When you lean left or right, the effect will be the transmission reducing the motor speed of the left or right track. The result is a smooth, controlled turn.

The Throttle needs to be engaged for the steering to function. Throttle engagement increases the amount of power to the motor which increases the RPM of the motor which in turn ultimately controls the steering along with the deck control.

The best way to learn how to ride the DTV Shredder is to start in a wide open, off-road, level riding area without any obstacles or safety risks to you or others. Steering will engage when your Shredder reaches a slow walking speed. Practice turning left and right at slow speeds in a figure “8” pattern so you comfortably develop your riding skills before increasing speed or riding on more challenging terrain.

The Dual Track setup applies an impressive 1.1 pounds per square inch of pressure on the ground. With 416 square inches of track touching the surface it is important to be aware of the rate of deceleration of the Shredder when you disengage the thumb throttle, also known as engine braking.

For most riders, the basic riding skills can be developed in about 30 minutes. As with any Powersports, the more you ride, the better you get at riding

RIDING THE SHREDDER

Riding on Hills

Climbing a Hill

Before climbing a hill, stop and evaluate the hill before attempting. Make sure the hill is not too steep, the terrain is not loose or slippery and that there are no obstacles. Approach the hill at a steady speed and maintain speed throughout the climb. Shift your body weight forward during the climb to ensure the front of your tracks maintains contact with the ground surface. You also may want to adjust the angle of the handle forward using the handle lock release lever (as seen on page 5 of your owner's manual). When approaching the top of the hill, reduce the throttle as the gravitation resistance decreases. DO NOT try and turn around while climbing a hill as this may cause your DTV Shredder to roll over which could be hazardous.

Descending a Hill

Before descending a hill, stop and evaluate the hill before attempting. Make sure the hill is not too steep, the terrain is not loose or slippery and that there are no obstacles. Place your body weight on the rear of your DTV Shredder and adjust the angle of the handle backwards using the handle lock release lever (as seen on page 5 of your owner's manual). Drive downhill slowly and apply just enough throttle to keep the clutch engaged. This will allow engine compression to help slow the machine and prevent your DTV Shredder from rolling freely.

Traversing a Hill

Traversing is an advanced maneuver due to the fact that leaning uphill also causes uphill steering simultaneously. Only attempt traversing with the recommended safety gear, and after you feel comfortable enough with your riding skill level.



WARNING

Riding a DTV on hills could be hazardous

Riding a DTV on a hill could result in rolling over while traversing, flipping over backwards while climbing, flipping over while descending, and general loss of control of the DTV. Any of these accidents on a hill could result in severe injury or death.

Never operate a DTV on steep hills. Practice riding the DTV on small hills using the hill riding techniques listed in this owner's manual.

26



WARNING

Traversing a hill improperly could be hazardous.

Traversing a hill improperly could result in losing control and flipping the DTV over. This could result in severe injury or death.

RIDING THE SHREDDER

Riding Over Obstacles

You are almost certain to meet obstacles on most trails, if you meet an obstacle that is too large, turn the DTV around and do not attempt it. If an obstacle is not too large and you have the knowledge and ability (knowing the proper technique), you can cross it by applying the following steps:

1. Go slow while approaching the obstacle.
2. Right before the obstacle give the DTV some throttle and pull back on the handlebars so the tracks go up over the obstacle.
3. Keep going slowly until the rear of the track clears the obstacle.

Never attempt to traverse a hill that is too steep or has loose or slippery terrain. Always follow the riding techniques listed in this manual for traversing a hill. Never attempt to traverse a large hill without first practicing on a small hill.



WARNING

Riding over large obstacles could be hazardous.

Riding over large obstacles could cause loss of control and cause the DTV to turn over which could result in severe injury or death.

Never attempt to ride over large obstacles, such as large rocks or fallen trees. Always make sure to follow the instructions in this manual when riding over obstacles.

RIDING THE SHREDDER

Going Reverse

Before going in reverse, use care to make sure the area is clear of people and obstacles. Flip the drive switch to reverse and press the thumb accelerator gently to start in reverse. Note that you must be stopped to flip from drive to reverse or from reverse to drive.



WARNING

Always ensure you're aware of your surroundings when going reverse. Watch out for people and obstacles.

RIDING THE SHREDDER

Riding Through Water

29 Riding through water can be hazardous and can cause damage to the DTV Shredder if the water is too deep or your speed is too high. Prior knowledge of your terrain is critical to avoiding injury and or damage to your DTV Shredder. Ensure the water you are riding through is no more than 3-inches (10cm) deep. Ensure sure you are travelling slowly as to not allow water to enter the inside of the vehicle. Before crossing any water area, inspect the terrain entering and exiting the water area, the terrain should have a gradual slope with no obstacles. The bottom of the shallow water should be solid. If you are unsure of the water depth or terrain, do not enter the water.



WARNING

Applying the brake hard on slippery surfaces could be hazardous.

Applying the brake too hard on a slippery surface can cause the Track to lock up and the DTV to slide out of control. The DTV could turn over or slide into an object. This could result in severe injury or death.

Gently apply the brakes when on a slippery surface.



WARNING

Skidding or sliding of the DTV could be hazardous.

Skidding or sliding could result in the DTV sliding into an object or overturning suddenly by regaining traction resulting in severe injury or death.

Practice controlling skidding or sliding by following the instructions in this manual.

Practice on a flat level dirt surface

Some surfaces are extremely slippery such as ice and snow. On these types of surfaces, go slow, and use caution.



WARNING

Riding this DTV through fast or deep water could be hazardous.

Deep or fast-moving water could cause the DTV to lose traction resulting in loss of control which could lead to severe injury or death.

Never operate this DTV in water that is more than 10cm (3in) deep. Never operate this DTV in fast moving water. Always check brakes after riding through water, wet brakes can reduce stopping ability.

Make sure brakes are dried out. The brakes can be dried out from friction by applying the brakes multiple times.

RIDING IN COLD WEATHER

Proper Clothing

Plan for and dress for the worst weather conditions. Your full attire should be similar to what someone would wear on a snowmobile in sub-zero temperatures. Insulated snowmobile protective gear is specially designed for cold temperature riding where wind-chills can be considerably colder than standing temperatures.

Pre-Ride Inspection

Brake and Throttle Linkages:

Cold weather requires additional pre-ride inspection of your DTV Shredder before riding. Inspect brake and throttle linkages making sure they operate freely and correctly. Ice and snow can cause these items to freeze. If the linkages are frozen, move your DTV Shredder to a warm area until these items thaw and can function properly.

Frozen Tracks: Check to make sure your DTV Shredder tracks are not frozen to the ground, if they are, pour warm water around the tracks to release the tracks from the ground. Do not attempt to remove your DTV Shredder from the ice using engine power, this could damage the engine and drivetrain.

Brake Inspection: Start engine and allow to warm up. Check the braking ability of the DTV by applying the brakes on level ground while travelling at a slow (walking rate) of speed. If the brakes do not work, take the DTV to a warm area to thaw out. Once brakes are thawed, check again for proper operation, if they still do not work, take the DTV to an authorized service center. Do not attempt to ride the DTV with brakes that do not function correctly. Preventive maintenance in cold weather riding is important. When riding in cold weather with snow, slush, water, or ice – dry off your DTV Shredder including brake and throttle linkages. Apply the brakes several times to ensure the friction has dried off the brake pads and shoes. Cover your DTV Shredder with a protective cover so ice and snow cannot accumulate.

RIDING THE SHREDDER

Cold Conditions Start Up

In the case of cold conditions follow these steps:

1. Before ride start the Shredder.
2. Before ride run the Shredder back and forth in a straight line.
3. Before beginning the ride test to make sure the Shredder is functioning properly.

Note: Depending on ambient temperature and environmental conditions the Shredder may take longer to warm up.

Note: Store shredder in warm, dry areas when possible.



RIDING IN COLD WEATHER

Riding on Snow and Ice

Be sure to clear the deck and soles of your boots of excess snow and ice before riding.

Practice riding the DTV on snow and ice on a flat, obstacle free, familiar area. Learn how the DTV responds in these conditions before attempting to ride on any ice or snow covered trails. Go slow and practice turning and responding to sliding and skidding as explained in this owner's manual.

Snow and icy sunny conditions are extremely bright, wear shaded eye protection such as a tinted face shield or goggles to help protect your eyes from the harmful rays of the sun. This will also will help you see better.

NOTE: Follow "Cold Conditions Start Up" page for proper cold conditions start up.



WARNING

Riding on a frozen lake or river could be hazardous.

The ice on a frozen lake or river could break causing the DTV to fall through which could result in severe injury or death

Always check the thickness of the ice by consulting with local authorities on ice conditions



CAUTION

Deck (standing platform) should be cleared from Snow and Ice build up to reduce risk of slipping off.



WARNING

Riding on terrain that is covered with snow could be hazardous.

Terrain covered with snow can hide obstacles such as holes, large rocks, logs etc. Running into one of these obstacles could result in loss of control which could result in severe injury or death.

Always go slow when riding over snow covered terrain, be alert to changing terrain.

LOADING GUIDELINES

Never exceed the maximum load capability of the DTV. This includes the weight of the rider and any cargo. This DTV is rated at 250 lbs. (114kg).

Do not add any accessory or cargo to the handlebars that could impede vision or make the DTV harder to steer.

Make sure accessories do not get in the way of any controls of the DTV.

Only carry cargo that is not bulky or too heavy.

Make sure all cargo is held securely in place, loose cargo can become a hazard.

While carrying cargo, go slow. Cargo can adversely affect handling at higher speeds.

Allow plenty of distance to stop while carrying cargo, the more weight on the DTV, the longer distance it will take to stop.

After Market Parts

After-market parts and accessories may be available from other manufacturers. DTV Motor Corp cannot confirm the quality, safety, or suitability of accessories available. When purchasing an accessory, use caution, the handling of the DTV could become affected. Some accessories may make the DTV unsafe to ride. If you have a question about a modification or accessory, contact your dealer or call DTV Motor Corp.



WARNING

Maximum Towing Capacity - 300lbs
Maximum Towing Speed - 10km/h(6mph)
Maximum Terrain Angle - 20deg
Tongue Weight - 10-15% of total loaded trailer weight

DO NOT use the DTV to tow objects without a trailer.

Always use an appropriate trailer and hitch for towing.

When using a receiver draw bar, never exceed a 2" height increase.

MAINTENANCE

Your DTV may be maintained by an authorized DTV Motor Corp service dealer or a repair shop of your choosing.

Following the proper maintenance procedures and timetable for maintenance listed in this manual is important for the safety of the rider and the service life of the DTV. When riding in harsh conditions, such as water, mud and dust, maintenance procedures should be performed more often.

WARNING

Failing to perform the recommended maintenance on this DTV could be hazardous.

Failing to perform proper maintenance on this DTV could result in an accident.

Always perform the recommended maintenance for the DTV as listed in this manual.

WARNING

Performing maintenance and inspection while the motor is running could be hazardous.

Performing maintenance and inspection while the motor is running could result in getting body parts or clothing caught in moving parts or could result in touching hot items which could result in severe injury.

Shut off the motor while performing maintenance and inspection checks, with the exception of checking the motor stop switch and throttle.

Prior to performing any work on this DTV ensure all batteries are unplugged and secured in a way to not accidentally power on the DTV or have any unintentional discharge.

CAUTION

Failing to perform recommended maintenance on this DTV could damage the DTV engine and components.

Failing to perform proper maintenance on this DTV could result in an accident.

Maintenance will need to be performed more often if ridden in wet, muddy, or dusty conditions.

CAUTION

Failing to use compatible parts with the original replacement parts could damage DTV.

Using parts that are of low quality could result in DTV breakdowns and reduce the useful life of the DTV.

Never use parts that are not compatible with the original parts.

MAINTENANCE

2023 E-DTV SHREDDER MAINTENANCE SCHEDULE

I = INSPECT & CLEAN/ADJUST/REPLACE/TIGHTEN AS NECESSARY L = LUBRICATE R = REPLACE DS = DEALER SERVICE						
ITEM	BEFORE EACH RIDE	FIRST 5 HRS OF USE	EVERY 15 HRS OR 3 MONTHS	EVERY 50 HRS OR 6 - 12 MONTHS	EVERY 125 HRS OR 2 YEAR	REMARKS
GENERAL						
TRACKS	I				R	Replace if tears or other damage is visible
TRACK DRIVE SPROCKETS	I			R		Replace if any part of the track drive sprocket is broken, damaged, or severely worn
TRACK DRIVE SPROCKET HUB-MOUNTING BOLTS	I			R		These should be tightened periodically because are clamping plastic under high loads
BRAKE LEVER FREE PLAY	I					Ensure brake lever has proper action to engage brakes fully
BRAKES PADS/ROTORS	I					Note: the left side pads and rotor are more exposed to the elements and may wear out quicker
BRAKE LINES/FLUID LEVEL				I/R		Be sure to check the splitter T-connection is not leaking fluid
CHAINS/SPROCKETS/PINIONS	I/L			R		See chain/sprocket replacement section
CHAIN GUIDE ASSEMBLIES	I/L			R		Ensure the idle sprocket is securely fit to and running smoothly on the bearing, otherwise replace entire assembly
FASTENERS	I					
MOTOR PHASE WIRES	I					Check for exposed/ damaged Wires
COOLANT	I					Ensure sufficient coolant level in coolant reservoir
COOLING SYSTEM	I					Check for leaks, cracks in hoses and radiator
HANDLE TOOTH-LOCK MECHANISM	I/L			R		Check for full engagement of teeth. Both top and bottom half should be replaced as a pair if any teeth are broken, damaged or worn
HANDLE LOCK & THROTTLE CABLES	I		L			Ensure cable had smooth action and returns naturally
HANDLE LOCK BOLT	I		R			Ensure this is tight
DECK				I		Check for cracks forming under the stomp pads
ELECTRICAL WIRES	I					Check for cracks. Reinstall or replace if necessary

MAINTENANCE

STEERING SENSOR HOUSING	I					Ensure steering performance is not degraded over time. If necessary, tighten all fasteners in deck pivot assemblies, steering sensor.
SHOCKS (+FASTENERS)	I					Ensure spring preload collars and all mounting fasteners are tight
THROTTLE CABLE	I		L			Ensure cable had smooth action and returns naturally. Ensure enough free play so throttle is not opened when handle folded down
BOGIE WHEELS/BEARINGS			I			Check behind covers and remove build-up
GREASE FITTINGS			L			
MIDDLE SUSPENSION MAIN PIVOT BUSHINGS			I	R		Check side to side play of the middle suspension assembly and ensure scissor-arms are not scraping against Engine intake duct

36

TRANSMISSION						
TRANSMISSION BELTS				R	I/R	
TRANSMISSION PULLEIES				R		
TRANSMISSION BEARING				R		
TRANSMISSION CASE DRAIN PLUG	I					Remove drain plug to ensure no liquid present after riding in rain, or after washing.
TRANSMISSION CASE				I		Remove any debris build-up inside case
ITEM	BEFORE EACH RIDE	FIRST 5 HRS OF USE	EVERY 15 HRS OR 3 MONTHS	EVERY 50 HRS OR 6 - 12 MONTHS	EVERY 125 HRS OR 2 YEAR	REMARKS
I = INSPECT & CLEAN/ADJUST/REPLACE/TIGHTEN AS NECESSARY L = LUBRICATE R = REPLACE DS = DEALER SERVICE						

MAINTENANCE

Brakes

This DTV is equipped with hydraulic disk brakes.

Brake Fluid

The brakes are hydraulic and require special tools to fill the lines. If brake pressure needs to be increased see dealership for service.

⚠️ WARNING

Failing to inspect the brakes before each use could be hazardous.

Inspect brakes before each use according to the Pre-Ride Inspection Chart, make sure to follow the maintenance schedule and procedures.

Steering Resistance

Adjusting the deck tilting resistance is accomplished through the pivot bolt. Turning the bolts clockwise will make deck tilt feel stiffer, which is better suited for heavier riders or for more stability at high speeds. Turning the bolts counter-clock-wise will make deck tilt easier.

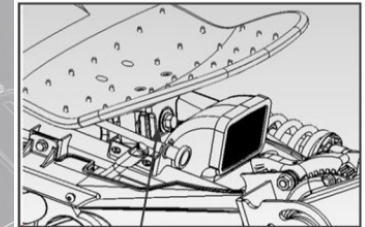

Pivot Bolts

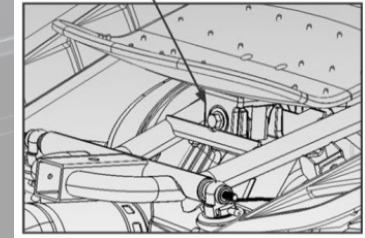

MAINTENANCE

Chain and Sprocket

Chain and Sprocket Inspection

Inspect the drive chain for wear, rust, bound links, proper lubrication and proper tension.

If the drive chain has a problem correct or replace. Contact a service center for chain replacement.

A worn drive chain could also mean the sprockets may be worn.

Look for the following on the sprockets:

Worn teeth

Broken or damaged teeth

Loose sprocket mounting nuts.

If the sprocket shows signs of wear, contact a service center for replacement.

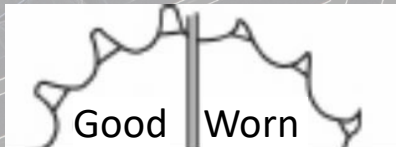

Chain Tension

Check the tension of the chain, The Chain slack should be 5 - 15mm (0.2 - 0.6in)

Chain Tension (Slack) Adjustment

1. Loosen the rear axle bolt
2. Adjust chain tension by turning the chain tension nut. Clockwise will tighten the chain. Counter clockwise will loosen the chain.
3. Once the chain is at the correct tension re-tighten Axle bolt (see torque spec chart)
4. Re-check chain tension.

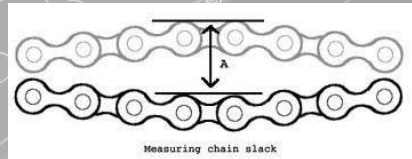

5 - 15mm (0.2 - 0.6in)

Chain Lubrication

Lubricating the Chain before each ride will help to ensure maximum life of the Chain and sprocket.

Instructions for Cleaning and Chain lubrication

1. Clean chain with a chain cleaner
2. Lubricate chain with chain lube before each ride.

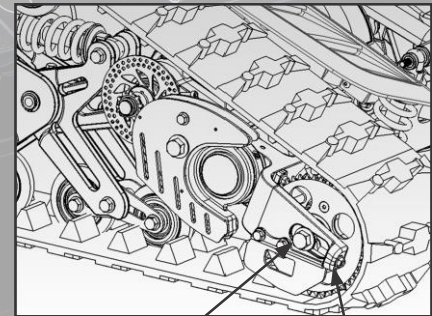

MAINTENANCE

Tracks

Track Inspection

Inspect Tracks before each ride for cracks or frayed threads.

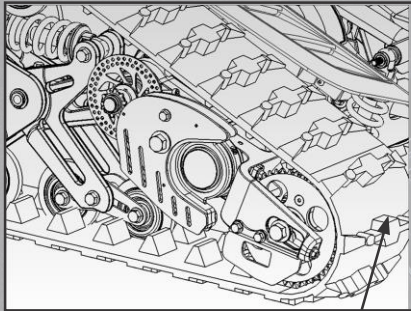

Track

Track Tension - Adjustment

1. Loosen track clamping bolt
2. Adjust track tension with adjustment screw
3. Tighten clamping bolt

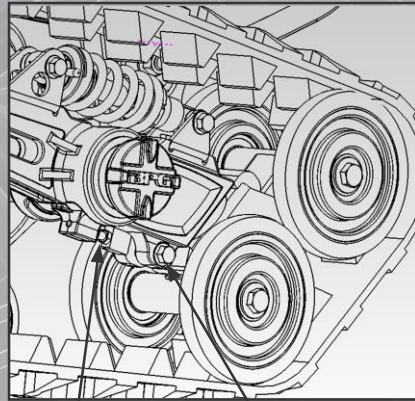

Track tension

Front swingarm track clamping bolt

Track Cleaning/Lubrication

To reduce the rolling friction of the tracks they should be cleaned and lubricated on the inside after use using a common automotive "tire shine" spray-on product.

! WARNING

Operating this DTV with excessive cracks or frayed threads in the tracks could be hazardous.

Operating this DTV with worn tracks will reduce traction which could result in an accident.

MAINTENANCE

Tracks

Track Replacement

Before attempting to put the track on by yourself, seek assistance. A second person holding the DTV tilted on an angle will make the process a lot easier with one track off the ground.

1. Remove the two front outside bogie wheels using a 13mm wrench .
2. Place track back in position ensuring it is fully engaged in the drive sprocket and in the correct position around the upper and lower bogie wheels. Then push the track over the front bogie wheels. Rotating the track can help the track slide on more easily.
3. Replace the two front outer bogie wheels making sure the bolts are tight.
4. The track may have come off due to insufficient tension. Follow the track tensioning instructions to increase the track tension. Ensure the track tension is equal on both sides.

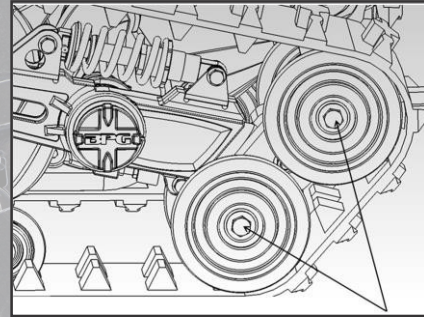

Bogey
Wheels

MAINTENANCE

Lubrication Points

Locate the Grease points on the DTV. Lubricate points periodically. Lubricate more often if riding in wet, sandy or dusty environments.

41 When lubricating the rear swingarm disconnect the shock at the bottom and rotate the swingarm up and down while pumping.

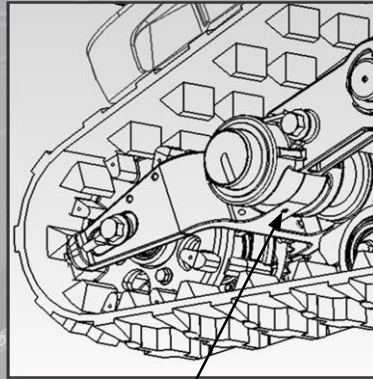

Rear Swing Arm Grease Points

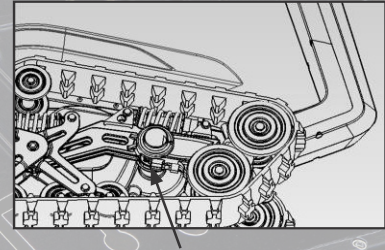
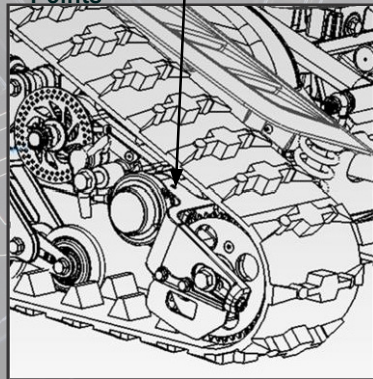

Front Swing Arm Grease point

MAINTENANCE

Fastener Torque Values

FASTENER TYPE	TORQUE VALUE (N-m, kgf-m, lb-ft)
5mm hex bolt and nut	6 Nm, 0.62 kgf-m , 4.5 lb-ft
6mm hex bolt and nut	10 Nm, 1.04 kgf-m, 7.5 lb-ft
8mm hex bolt and nut	30 Nm, 3.05 kgf-m, 22 lb-ft
10mm hex bolt and nut	40 Nm, 4.07 kgf-m, 29 lb-ft
12mm hex bolt and nut	60 Nm, 6.11 kgf-m, 44 lb-ft
5mm screw	6 Nm, 0.62 kgf-m , 4.5 lb-ft
6mm screw	10 Nm, 1.04 kgf-m, 7.5 lb-ft
8mm screw	30 Nm, 3.05 kgf-m, 22 lb-ft

Fig. 1

MAINTENANCE

Storage

If the DTV is left unused for an extended period of time proper storage maintenance is required.

1. Wash DTV thoroughly, then wax plastics and painted parts with a non-abrasive auto wax. Coat rubber parts with a vinyl/rubber protectant.
2. If possible, store DTV in a shed or garage with a cover to protect from dust, dirt and humidity. If the DTV must be stored outdoors, cover DTV completely with a good waterproof cover.
3. The DTV Battery needs special consideration for short- and long-term storage. Please follow these procedures for long- and short-term storage:

Note: Keep water away from wheels and bearings as this can cause corrosion and seizing.

Short term Storage (less than 8 weeks):
Disconnect the battery from the vehicle and store it in a location which is suitable for Lithium-Ion batteries. See the battery section for more information.

Long Term Storage (longer than 8 weeks):
The DTV can be plugged in with the batteries connected internally with the 5A battery Charger. The battery charger can keep the batteries charged for long periods. It is recommended to check the individual battery packs to ensure all packs are evenly charging at least for the first 4 weeks. Even though the charger can help with long term storage, it is the owner's responsibility to ensure that the batteries don't become damaged from a low voltage condition which can permanently damage the batteries. Adding a timer to help efficiently charge the batteries can also be considered. DTV Motor Corp can supply additional devices for long term storage such as Y-connectors for out of vehicle charging as well.

Returning to Service

1. Wash DTV thoroughly. Keep water away from wheels and bearings as this can cause corrosion and seizing.
2. Review this owner's manual and follow the pre-ride inspection procedures.
3. Check Battery levels and Charge Batteries individually for first time use.

MAINTENANCE

Washing the DTV

1. Wash mud and dirt off DTV with low pressure water from a hose .
2. Wash DTV using a mild automotive soap with soft rag or brush. Do not use any cleaning materials that could scratch the DTV.

DO NOT point a nozzle directly at the motors, electrical wires, chains, sprockets and bearings.

Transporting

1. Fold down DTV handle for storage and transportation.
(Use handle lock release lever to release handle)

Handle Lock Release Lever

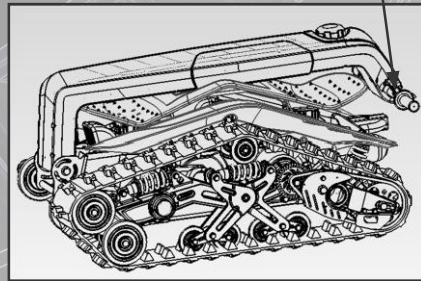

Transport Position

Note:

To reduce the rolling friction of the tracks they should be cleaned and lubricated on the inside after use using a common automotive “tire shine” spray-on product.

After washing, it is recommended to lube the chains and bearings before storage. This ensures maximum life and service of the parts. Use motorcycle wax for the chains and WD40 for the bearings.



CAUTION

Never wash the DTV with a power washer.

High pressure will penetrate bearing and O-ring chain seals which will cause damaged to the DTV.

TROUBLESHOOTING

Motor Lacks Power

1. Ensure Tracks are not jammed.

Poor Steering Performance

1. Ensure there are no rocks or debris blocking the motion of the deck.
2. Make sure that you follow the “Steering Technique” section.

Brake Adjustment

1. Always ensure there is enough **Free-Play** with the **Brake Lever**. (free-play should be about 1/2 of total travel)
2. Always ensure brakes have not **Locked Up** because of increased temperature .



SPECIFICATIONS

Motor

Motor(single):

12.5kw

Top Speed

40km/h (25mph)

Battery

Type: 12S Lithium-Ion Battery

Operating temperature range: -20°C to

+50°C Storage conditions: -5°C to

+35°C, and less than 75% relative humidity.

Transmission

18 Teeth L series - Small Sprocket

48 Teeth L series - Large Sprocket

61 Teeth L series Belt

88 Teeth L series Belt

Suspension

Type 6 Hydraulic shocks

Braking

Hydraulic Disk

Dimensions and Weights

Length:

Handle down 1150mm (45 in.)

Handle up 1321mm (52 in.)

Width 678mm (27 in.)

Height:

Handle down 584mm (23 in.)

Handle up 1270mm (50 in.)

Vehicle Wt. 115kg (250lbs)

Weight Cap. 113kg (250lbs)

Vehicle Operating Temperature

-20°C to +30°C

Vibration

The vibration on handles does not exceed 2.5m/s².

Standards

This product is in conformity with the following European standards:

- EC Machinery Directive (206/42/EC)
- EC EMC Directive (2004/108/EC)
- Applied Harmonized Standards: EN ISO 12100
- CE AOC (attestation of compliance)
#12 12 82909 001

WARRANTY

OWNER'S WARRANTY RESPONSIBILITIES

As the small off-road vehicle owner, you are responsible for the performance of the **required maintenance listed in your owner's manual**. DTV Motor Corp recommends that you retain all receipts covering maintenance on your small off-road vehicle, but DTV Motor Corp cannot deny warranty solely for the lack of receipts or for your failure to ensure the performance of all scheduled maintenance.

As the small off-road vehicle owner, you should however be aware that DTV Motor Corp may deny you warranty coverage if your small off-road vehicle or a part has failed due to abuse, neglect, improper maintenance or unapproved modifications.

47 This warranty covers parts and labor charges for repair or replacement of defective parts and begins on the date of purchase by the original retail purchaser. This warranty is transferable to another owner during the warranty period through a DTV Motor Corp dealer, but any such transfer will not extend the original term of the warranty. The duration of this warranty may vary by international region based upon local laws and regulations.

At the time of sale, the Warranty Registration Form must be completed by your dealer and submitted to DTV Motor Corp within ten days of purchase. Upon receipt of this registration, DTV Motor Corp will record the registration for warranty. No verification of registration will be sent to the purchaser as the copy of the Warranty Registration Form will be your proof of warranty coverage. If you have not signed the original registration and received the customer copy, please contact your dealer immediately. **NO WARRANTY COVERAGE WILL BE ALLOWED UNLESS YOUR VEHICLE IS REGISTERED WITH DTV Motor Corp.**

WARRANTY CONTINUED

LIMITATIONS OF WARRANTIES AND REMEDIES This DTV Motor Corp limited warranty excludes any failures that are not caused by a defect in material or workmanship. **THIS WARRANTY DOES NOT COVER CLAIMS OF DEFECTIVE DESIGN.** This warranty also does not cover acts of God, accidental damage, normal wear and tear, abuse or improper handling. This warranty also does not cover any vehicle, component, or part that has been altered structurally, modified, neglected, improperly maintained or used for racing, competition or purposes other than for which it was designed. This warranty excludes damages or failures resulting from improper lubrication, surface imperfections caused by external stress, heat, cold or contamination; operator error or abuse; improper component alignment, tension, adjustment or altitude compensation; snow, water, dirt or other foreign substance ingestion/contamination; improper maintenance; modified components; use of aftermarket or unapproved components, accessories, or attachments; unauthorized repairs; or repairs made after the warranty period expires or by an unauthorized repair center. This warranty excludes damages or failures caused by abuse, accident, fire, or any other cause other than a defect in materials or workmanship and provides no coverage for consumable components, general wear items, or any parts exposed to friction surfaces, stresses, environmental conditions and/or contamination for which they were not designed or not intended.

48

You are responsible for presenting your vehicle to a DTV Motor Corp dealer or distribution center as soon as a problem exists. If you have any questions regarding your warranty rights and responsibilities, you should contact DTV Motor Corp at one of the following:

DTV Motor Corporation
www.dtvmotorcorp.com
sales@dtvmotorcorp.com

WARRANTY

Wear Items with no Warranty	Labor	1-Year Warranty Items	Labor
Tracks and Drive Parts (chains & Sprockets etc.)	None	Transmission Components (non wear)	90-days
Transmission Belts	None	Frame	90-days
Middle Suspension Bushings/ Bearings	None	Handle	90-days
Brake System	None	Batteries (Unless low voltage condition)	90-days
Throttle Assembly	None	Motors	90-days
Grease Fittings	None	Cooling system	90-days
All Chain Drive Parts	None	Wiring Harness	90-days
Skid Plate	None	Battery connectors and cables	90-days
Handle Lock Parts	None		90-days
Steering Linkages	None		90-days
Ice Breakers	None		90-days
Bogey Wheels and Bearings	None		90-days
Battery holders	None		
Controller Unit	None		
Brake System	None		

All Warranties are for manufactures defects. Neglect or abuse of the DTV Shredder may void warranty. DTV Motor Corp reserves the right to decline warranty coverage. Vehicles subjected to severe use must be inspected and serviced more frequently. Severe use Definition: 1. frequent immersion in mud or sand 2. Racing or race style high RPM use 3. Prolonged low speed 4. Heavy load operation 5. Extended idle 6. Short trip cold weather operation 7. Extreme heat environments 8. Commercial use. 9. Water immersion resulting in water Ingress.

WARRANTY

VIN Location

The Vehicle identification number and the engine number are needed when calling for parts, service center help or when registering your DTV. Locate the numbers and list the numbers below for your reference.

The VIN# is located on top of the trailer hitch receptacle.

Vehicle Identification Number

--	--	--	--	--	--	--	--	--	--	--	--	--	--	--	--	--	--

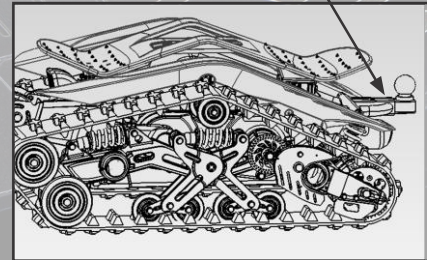

MAINTENANCE



51

DTV Motor Corporation
Dtmotorcorp.com