



FIRST USE GUIDE

Congratulations on your purchase of the DTV Shredder! It is in your best interest to read through the First Use Guide for optimal experience and safe use of the Shredder.

It is a requirement for all users to read the Owner's Manual before operating the DTV Shredder. This is a brief overview to get the user familiar with the machine and is NOT a substitute for the Owner's Manual. The information provided here is based on the latest product data available at the time of publishing. Visit DTVMOTORCORP.COM to ensure your guides and manuals are of the latest version.

Start Up Procedure

Make sure sufficient oil (5w-40) is in the engine by checking the level on the dipstick.

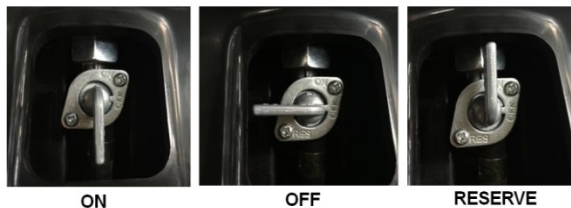

Put the fuel valve in the ON position, and fill the gas tank with 91 octane ethanol-free fuel. If you run out of fuel when riding, switch the fuel valve to the RESERVE position. You should get approximately 10mins of running at a quarter throttle speed.



Turn the START switch on. Press the primer bulb once to inject fuel into the engine. Press the START button and feather the throttle slowly to start the engine. If the engine struggles to start, press the primer once more and try again. This is usually required for cold weather starts. Do not press the primer more than twice as this will fill an excessive amount of fuel into the engine and prevent start up.

If the electric start fails, there is a pull start cable located on the front right side of the shredder. With the starter switch on, pull the cable quickly and firmly until the engine starts up.

Chains and tracks

Make sure the chains are sufficiently tight. Allow for 10mm slack. Similarly, track tension should be checked prior to riding. Both tracks should have equal stiffness. The tracks will stretch over time as they break in. To adjust chain and track tensions refer to the Owner's Manual.

CHAIN ADJUSTMENT

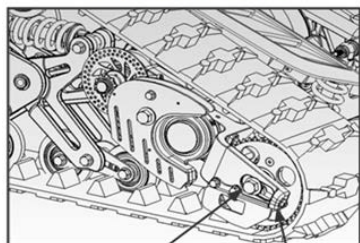

Rear Axle Bolt

Chain Tension Nut

TRACK ADJUSTMENT

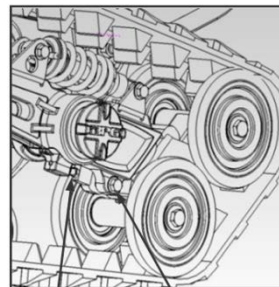

Track Tension
Adjustment Screw

Front Swingarm
Clamping Bolt

Riding Safety

Always wear appropriate full body protective gear and hearing and eye protection along with a DOT/Snell certified helmet before operating the DTV Shredder. A safety lanyard has been designed to immobilize the Shredder in case of emergency dismounts. Before starting the Shredder, make sure to fasten the lanyard to the rider in the proper position.

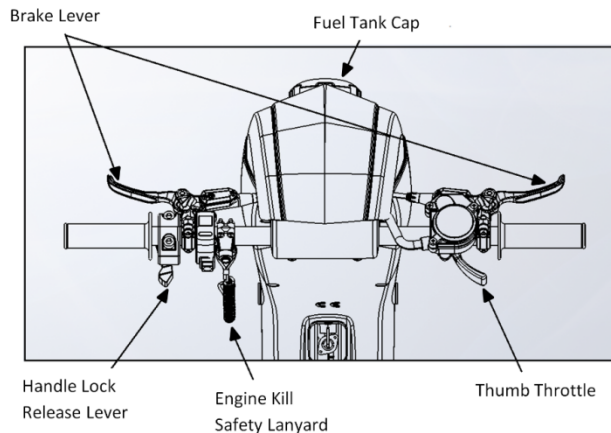

Start on flat obstacle-free ground and practice smooth acceleration and stopping at low speeds. Throttle control is critical to optimal experience and overall safety of the rider. Do not touch the brake when moving. Engine braking is usually sufficient to quickly bring the Shredder to a halt. As with all powersports vehicles, make sure to take your time and familiarize yourself with the machine. Refer to the owner's manual for full safety procedures on the operation of the Shredder.

Steering

Gradually practice shifting your weight and body position to initiate and hold turns. Avoid aggressive leaning until you are comfortable with the throttle response and steering. Steering is speed sensitive. At lower speeds tighter turns can be achieved. At higher speeds, more gradual steering is experienced with larger turning arcs for safety reasons. With aggressive deceleration, steering sensitivity kicks in quickly. Become familiar with the speed and steering before attempting high speed maneuvers.

If the Shredder steers easier towards one side than the other, the steering rod needs to be re-aligned to center the transmission. Refer to the owner's manual for this adjustment.

Check Engine Light

The Check Engine Light is located on the handle cover. There are specific codes used to communicate engine issues. These codes can be found in the owner's manual. If the light stays on, the engine is likely overheating. Shut off the Shredder and allow for a sufficient cool down period before turning the shredder on again. **DO NOT RIDE WITH THE CHECK ENGINE LIGHT ON.**



Track Derailment

Failure to maintain track tension can cause the track to slip off the track drive and bogey wheels. Before attempting to put the track on by yourself, seek assistance. A second person holding the Shredder tilted on an angle will make the process a lot easier with one track off the ground.

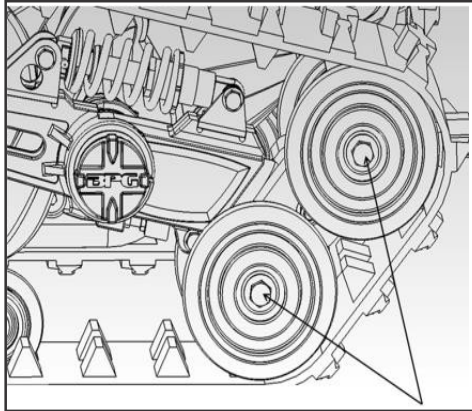

To put the track back on, a 13mm wrench is needed to undo the bolts on the main outside front two bogey wheels as identified in the image. The track can then be pushed back onto the drive.

Do not roll the Shredder onto its side. This can cause engine flooding. If you need the shredder on its side, put the fuel valve in the OFF position and run the engine out of fuel first. The Shredder can then be put on its left side. If the Shredder is rolled over on its right side it will cause fuel to enter the intake system. For more details on this procedure refer to the owner's manual.

Cleaning and Maintenance

Do not power wash the Shredder. A low pressure hose is sufficient to clean the unit for regular upkeep. Do not spray water inside the intake breather or the exhaust.

After every wash, it is recommended to lube the chains and bearings before storage. This ensures maximum life and service of the parts. Use motorcycle wax for the chains and WD40 for the bearings. See owner's manual for full maintenance instructions of the shredder.

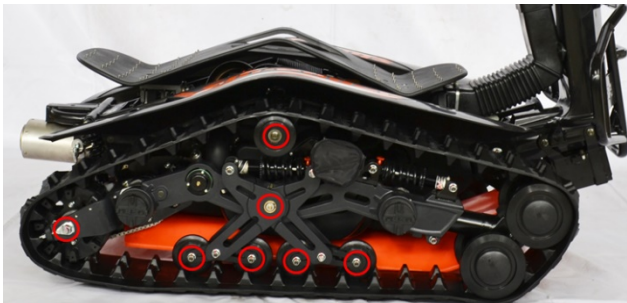

○ DO NOT AIM A PRESSURIZED NOZZLE DIRECTLY AT THE SHREDDER IN THESE AREAS. High pressure water can potentially damage the bearings and reduce its life cycle.

First Oil Change

Your DTV Shredder comes with conventional motor oil to break-in the engine components. It is imperative to change to full synthetic oil after the first 5-10 hours of riding. Use 5W-40 full synthetic premium oil. The oil filter is not required to be changed at this time. For step-by-step instructions on how to do an oil change, please refer to the Owner's Manual.